

MSI715

Mariner Kit for use with the HP E22 G5 FHD
21.5-inch Monitor (Wall mount)



The HP E22 G5 FHD Monitor is marine type approved when it is installed in conjunction with our Mariner Kit MSI715.

The MSI715 Mariner Kit is designed to fit onto any vertical surface and affords protection against the effects of vibration and shock experienced in the offshore marine environment. The combination has been type tested against IACS Unified Requirement E10 and the relevant sections of IEC60945 (see below right for test details).

This marine type approved combination of hardware and Mariner Kit can be used as the platform for your critical navigation, control, loading and general purpose applications.

Please note that although the monitor retains its standard functionality it is not fully dimmable and it cannot therefore be used in the front of the bridge where it may affect night vision. The monitor can however be used in any area where night vision is not an issue.

**“Steer the right course
with Mariner Systems”**



PRODUCT FEATURES

- ◆ Crafted to deliver crisp visuals, personalised comfort, and true flexibility
- ◆ No matter where you stand, IPS technology ensures image accuracy and consistency across wide, 178-degree horizontal and vertical viewing angles
- ◆ Keep your eyes comfortable with a monitor that comes with flicker-free technology, a 75Hz refresh rate and HP Eye Ease, an always-on, built-in low-blue light filter
- ◆ Connect to your most frequently-used devices with HDMI, and DisplayPort™
- ◆ Reaching highest energy-saving standards with an ENERGY STAR® rating and EPEAT® registration
- ◆ Low halogen display
- ◆ Supported by HP's three-year standard limited warranty
- ◆ Compliant with the Restrictions of Hazardous Substances (RoHS) directive – 2011/65/EU
- ◆ Designed to comply with the Waste Electrical and Electronic Equipment (WEEE) directive – 2002/96/EC

This Mariner Systems solution is tested against the consolidated, 'worst-case' requirements of all the following major international marine Classification Societies:

ABS, BV, CCS, ClassNK, DNV, KR, LR, PRS, RINA

Refer to individual Classification Society type approval certificates for any restrictions/limitations

Tests included within the test programme are as follows:

- > Vibration, Shock, Static and Dynamic Inclination
- > Dry & Damp Heat, Low Temperature
- > Acoustic Noise, Compass Safe Distance
- > High Voltage, Power Supply Variation & Power Supply Failure
- > Conducted LF & RF, Electromagnetic Field
- > Radiated & Conducted Emissions, Electrostatic Discharge
- > Insulation Resistance, Burst/Fast Transients
- > Surge Immunity, Access to Dangerous Voltages

MSI715

Mariner Kit for use with the HP E22 G5 FHD 21.5-inch Monitor (Wall mount)

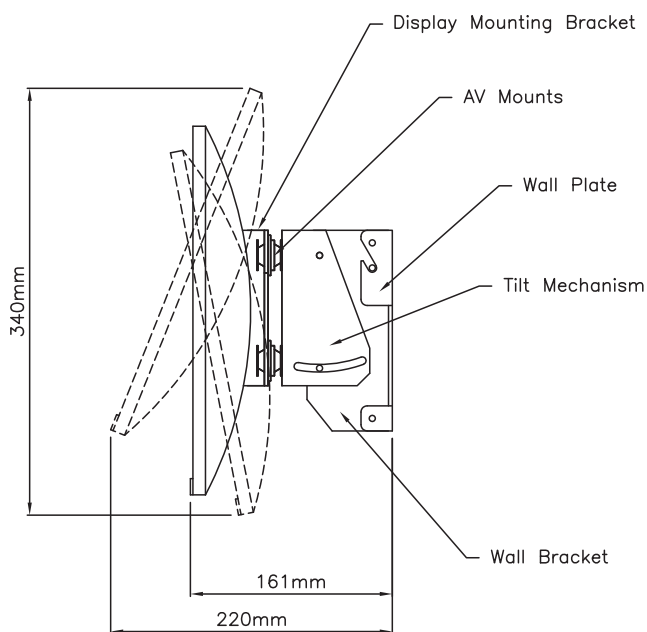
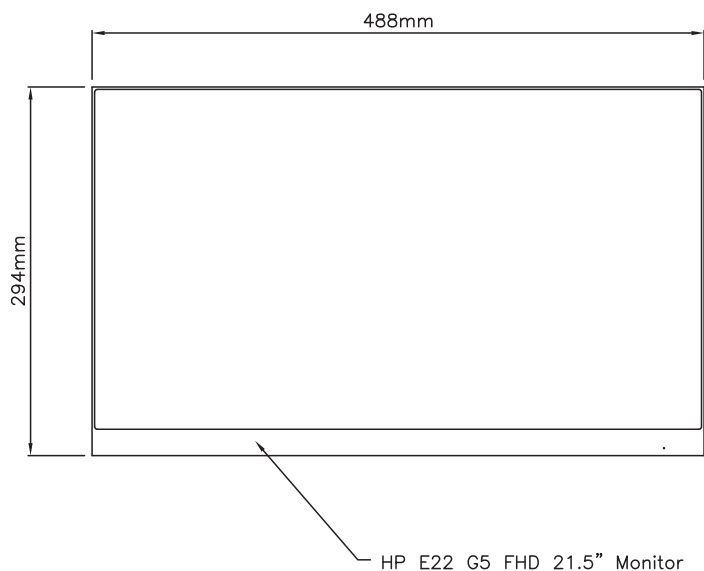

Mariner Systems (UK) Limited

Oaklands Park • Wokingham • Berkshire • RG41 2FD • United Kingdom
 Telephone: +44 (0) 118 979 6020 • Facsimile: +44 (0) 118 979 6021
 sales@marinersystems.com • www.marinersystems.com

OPERATING GUIDELINES

Although all of our solutions are tested against extreme environmental conditions for the purposes of marine type approval, installation should take into account the following guidelines:

- Keep the monitor away from excessive moisture, direct sunlight and the extremes of heat and cold. Wherever possible, ensure that the unit is operated within the manufacturer's recommended operating range:

	Operating	Non-Operating
Temperature	+5° to +35°C (+41° to +95°F)	-40° to +65°C (-40° to +149°F)
Humidity	20% to 80% (non-condensing)	5% to 95% (non-condensing)

- Leave clearance on all vented sides of the monitor to permit sufficient airflow
- Never restrict airflow into the monitor by blocking any vents or air intakes
- If the monitor is to be operated within a separate enclosure, suitable ventilation should be provided

By following these guidelines, you will maximise the life of your monitor and minimise service costs.

STATISTICS

Overall Fitted Dimensions (max)	488mm (w) x 340mm (h) x 220mm (d)
Weight (Mariner Kit only)	1.2 kg
Weight (including hardware)	4.1 kg
Panel Type	IPS
Viewable Image Area (diagonal)	21.5 in (54.6 cm)
Panel Active Area (w x h)	18.74 x 10.54 in (47.61 x 26.78 cm)
Aspect Ratio	16:9
Native Resolution	FHD (1920 x 1080 @ 75 Hz)
Viewing Angle	Up to 178 degrees horizontal and 178 degrees vertical
Brightness (typical)	250 nits
Contrast Ratio (static)	1000:1
Dynamic Contrast Ratio	8,000,000:1
Response Time (typical)	5 ms GtG (with overdrive)
Pixel Pitch	0.25 x 0.25 mm
Backlight Lamp Life (to half brightness)	30,000 hours minimum
Input Connectors	DisplayPort™ 1.2, HDMI 1.4, HDCP support on DisplayPort™ and HDMI
USB Ports	1 x USB Type-B; 4 x USB Type-A 3.2 (1 charging)
Input Power	100 to 240 VAC 50/60 Hz
Typical Power Consumption	20W
Maximum Power Consumption	50W
Mariner Kit Tilt Range	10 degrees down; 20 degrees up